



EMC TEST REPORT

On Behalf of

Prepared For :	Dongguan Haiwei Technology Co., Ltd Room 410, Unit 2, No.1, Pailou Ji Industrial Road, Wanjiang Street, Dongguan City, Guangdong Province
Trade Mark :	
Product Name :	Temperature and
Model(s) :	HW-6100G
Prepared By:	Shenzhen BYS Testing Co., Ltd. Floor 4, Building 2, No.38 Guangda Road, Yuanshan Street,Longgang district, Shenzhen, China
Test Date:	Mar. 15, 2022- Mar. 21, 2022
Date of Report:	Mar. 21, 2022
Report No. :	BYS2203150158ER

Note: This test report is limited to the above client company and the product model only. It may not be duplicated without prior written consent of Shenzhen BYS Testing Co., Ltd.



TABLE OF CONTENT

Description

Test Report Description

Page

1. GENERAL INFORMATION.....	4
1.1. Description of Device (EUT).....	5
1.2. Test Standards.....	5
1.3. Test Summary.....	6
1.4. Test Methodology.....	7
1.5. Test Facility.....	7
1.6. Measurement Uncertainty.....	7
2. MEASURING DEVICE AND TEST EQUIPMENT.....	8
2.1. For Power Line Conducted Emission.....	8
2.2. For Radiated Emission Measurement.....	8
2.3. For Harmonic Current / Flicker Measurement.....	8
2.4. For Electrostatic Discharge Immunity Test.....	8
2.5. For RF Strength Susceptibility Test.....	9
2.6. For Electrical Fast Transient /Burst Immunity Test.....	9
2.7. For Surge Immunity Test.....	9
2.8. For Injected Current Susceptibility Test.....	9
2.9. For Magnetic Field Immunity Test.....	9
2.10. For Voltage Dips and Interruptions Test.....	9
3. POWER LINE CONDUCTED EMISSION MEASUREMENT.....	10
3.1. Block Diagram of Test Setup.....	10
3.2. Measuring Standard.....	10
3.3. EUT Configuration on Measurement.....	10
3.4. Operating Condition of EUT.....	11
3.5. Test Procedure.....	11
3.6. Measuring Results.....	11
4. RADIATED EMISSION MEASUREMENT.....	14
4.1. Block Diagram of Test.....	14
4.2. Measuring Standard.....	14
4.3. Radiated Emission Limits.....	15
4.4. EUT Configuration on Test.....	15
4.5. Operating Condition of EUT.....	15
4.6. Test Procedure.....	15
4.7. Measuring Results.....	15
5. HARMONIC CURRENT EMISSION MEASUREMENT.....	18
5.1. Block Diagram of Test Setup.....	18
5.2. Measuring Standard.....	18
5.3. Operation Condition of EUT.....	18
5.4. Measuring Results.....	18
6. VOLTAGE FLUCTUATION AND FLICKER MEASUREMENT.....	19
6.1. Block Diagram of Test Setup.....	19
6.2. Measuring Standard.....	19
6.3. Operation Condition of EUT.....	19
6.4. Measuring Results.....	19
7. ELECTROSTATIC DISCHARGE IMMUNITY TEST.....	21
7.1. Block Diagram of Test Setup.....	21
7.2. Test Standard.....	21
7.3. Severity Levels and Performance Criterion.....	21



7.4 EUT Configuration..... 21

7.5 Operating Condition of EUT..... 22

7.6 Test Procedure..... 22

7.7 Test Results..... 22

8. RF FIELD STRENGTH SUSCEPTIBILITY TEST.....24

8.1 Block Diagram of Test..... 24

8.2 Test Standard..... 24

8.3 Severity Levels and Performance Criterion..... 25

8.4 EUT Configuration on Test..... 25

8.5 Operating Condition of EUT..... 25

8.6 Test Procedure..... 25

8.7 Test Results..... 25

9. ELECTRICAL FAST TRANSIENT/BURST IMMUNITY TEST..... 27

9.1 Block Diagram of Test Setup..... 27

9.2 Test Standard..... 27

9.3 Severity Levels and Performance Criterion..... 27

9.4 EUT Configuration..... 28

9.5 Operating Condition of EUT..... 28

9.6 Test Procedure..... 28

9.7 Test Result..... 28

10. SURGE IMMUNITY TEST..... 30

10.1 Block Diagram of Test Setup..... 30

10.2 Test Standard..... 30

10.3 Severity Levels and Performance Criterion..... 30

10.4 EUT Configuration..... 31

10.5 Operating Condition of EUT..... 31

10.6 Test Procedure..... 31

10.7 Test Result..... 31

11. INJECTED CURRENTS SUSCEPTIBILITY TEST..... 33

11.1 Block Diagram of Test Setup..... 33

11.2 Test Standard..... 33

11.3 Severity Levels and Performance Criterion..... 33

11.4 EUT Configuration..... 34

11.5 Operating Condition of EUT..... 34

11.6 Test Procedure..... 34

12. MAGNETIC FIELD SUSCEPTIBILITY TEST.....36

12.1 Block Diagram of Test..... 36

12.2 Test Standard..... 36

12.3 Severity Levels and Performance Criterion..... 36

12.4 EUT Configuration on Test..... 37

12.5 Test Procedure..... 37

12.6 Test Results..... 37

13. VOLTAGE DIPS AND INTERRUPTIONS TEST.....39

13.1 Block Diagram of Test Setup..... 39

13.2 Test Standard..... 39

13.3 Severity Levels and Performance Criterion..... 40

13.4 EUT Configuration..... 40

13.5 Operating Condition of EUT..... 40

13.6 Test Procedure..... 40

13.7 Test Result..... 40

Photos of EUT

**TEST REPORT DECLARATION**

Applicant	:	Dongguan Haiwei Technology Co., Ltd
Address :	:	Room 410, Unit 2, No.1, Pailou Ji Industrial Road, Wanjiang Street, Dongguan City, Guangdong Province
Manufacturer:	:	Dongguan Haiwei Technology Co., Ltd
Address :	:	Room 410, Unit 2, No.1, Pailou Ji Industrial Road, Wanjiang Street, Dongguan City, Guangdong Province
EUT Description :	:	Power environment monitoring host
Model Number	:	HW-6100G

Test Standards:

EN 55032:2015+A1:2020
EN 55035:2017+A11:2020
EN IEC 61000-3-2:2019+A1:2021
EN 61000-3-3:2013+A2:2021

The EUT described above is tested by BYS Testing Co., Ltd. EMC Laboratory to determine the maximum emissions from the EUT and ensure the EUT to be compliance with the immunity requirements of the EUT. Shenzhen BYS Testing Co., Ltd. is assumed full responsibility for the accuracy of the test results. Also, this report shows that the EUT technically complies with the 2014/30/EU directive and its amendment requirements.

The test report is valid for above tested sample only and shall not be reproduced in part without written approval of the laboratory.

Date of Test:

Mar. 15, 2022- Mar. 21, 2022

Prepared by (Engineer) :

ma luo

Reviewer by (Quality Manager) :

Jade

Approved by (Manager) :



1. GENERAL INFORMATION

1.1. Description of Device (EUT)

EUT : Power environment monitoring host

Trademark : 

Model : HW-6100G

Supplementary Model : /

Test Voltage : AC 220V 50 Hz

Rating : AC 75-250V, 50/60Hz

Applicant : Dongguan Haiwei Technology Co., Ltd
 Address : Room 410, Unit 2, No.1, Pailou Ji Industrial Road, Wanjiang Street, Dongguan City, Guangdong Province

Manufacturer : Dongguan Haiwei Technology Co., Ltd
 Address : Room 410, Unit 2, No.1, Pailou Ji Industrial Road, Wanjiang Street, Dongguan City, Guangdong Province

1.2. Test Standards

Test Standards	
EN 55032:2015+A1:2020	Information technology equipment- Radio disturbance characteristics- Limits and methods of measurement
EN 55035:2017+A11:2020	Information technology equipment- Immunity characteristics - Limits and methods of measurement
EN IEC 61000-3-2:2019+A1:2021	Electromagnetic compatibility(EMC)-Part 3-2:Limits-Limits for harmonic current emissions(equipment input current \leq 4000Wmax. per phase)
EN 61000-3-3:2013+A2:2021	Electromagnetic compatibility(EMC)-Part 3-3:Limits-Limitation of voltage changes, Voltage fluctuations and flicker in public low-voltage supply systems. For equipment with Rated current \leq 4000Wmax. per phase and not subject to conditional connection



1.3. Test Summary

For the EUT described above.

Table 1: Tests Carried Out Under EN 55032:2015+A1:2020

Standard	Test Items	Status
EN 55032:2010 +A1:2011	Disturbance Voltage at The Mains Terminals (150KHz To 30MHz)	√
	Radiated Disturbances (30MHz To 1000MHz)	√

- √ Indicates that the test is applicable
 × Indicates that the test is not applicable

Table 2: Tests Carried Out Under

Standard	Test Items	Status
EN61000-4-2:2009	Electrostatic discharge Immunity	√
EN61000-4-3:2006	Radiated Susceptibility (80MHz to 1GHz)	√
EN61000-4-4:2004+A1:2010	Electrostatic Fast Transient/Burst Immunity	√
EN61000-4-5:2006	Surge Immunity	√
EN61000-4-6:2009	Conducted Susceptibility (150KHz to 80MHz)	√
EN61000-4-8:2010	Power Frequency Magnetic Field Immunity (50/60Hz)	√
EN61000-4-11:2004	Voltage Dips Short Interruptions Immunity Tests	√

- √ Indicates that the test is applicable
 × Indicates that the test is not applicable

Table 3: Tests Carried Out Under EN IEC 61000-3-2:2019+A1:2021 & EN61000-3-3:2013

Standard	Test Items	Status
EN IEC 61000-3-2:2019+A1:2021	Harmonic Current	×
EN61000-3-3:2013	Voltage Fluctuations	√

- √ Indicates that the test is applicable
 × Indicates that the test is not applicable



1.4. Test Methodology

All measurements contained in this report were conducted with CISPR 16-1: 2002, radio disturbance and immunity measuring apparatus, and CISPR16-2: 2002, Method of measurement of disturbances and immunity.

All measurement required was performed at laboratory of SHENZHEN BYS TESTING CO., LTD,

1.5. Test Facility

The test facility is recognized, certified, or accredited by the following organizations:

The facility also complies with the radiated and AC line conducted test site criteria set forth in CISPR 16-1: 2002, CISPR16-2: 2002.

1.6.Measurement Uncertainty

Radiation Uncertainty : $U_r = \pm 3.84 \text{ dB}$

Conduction Uncertainty : $U_c = \pm 2.72 \text{ dB}$



2. MEASURING DEVICE AND TEST EQUIPMENT

2.1. For Power Line Conducted Emission

Item	Equipment	Manufacturer	Model No.	Serial No.	Last Cal.	Cal. Interval
1.	Test Receiver	Rohde & Schwarz	ESCS30	828985/018	Nov. 20, 2021	1 Year
2.	L.I.S.N	Rohde & Schwarz	ESH2-Z5	834549/005	Nov. 20, 2021	1 Year
3.	50Ω Coaxial Switch	Anritsu	MP59B	M20531	N/A	N/A
4.	Pulse Limiter	Rohde & Schwarz	ESH3-Z2	100006	Nov. 20, 2021	1 Year
5.	Voltage Probe	Rohde & Schwarz	TK9416	N/A	Nov. 20, 2021	1 Year

2.2. For Radiated Emission Measurement

Item	Equipment	Manufacturer	Model No.	Serial No.	Last Cal.	Cal. Interval
1.	Spectrum Analyzer	ANRITSU	MS2661C	6200140915	Nov. 20, 2021	1 Year
2.	Test Receiver	Rohde & Schwarz	ESCS30	828985/018	Nov. 20, 2021	1 Year
3.	Bilog Antenna	Schwarzbeck	VULB9163	142	Nov. 20, 2021	1 Year
4.	50 Coaxial Switch	Anritsu Corp	MP59B	6100237248	Nov. 20, 2021	1 Year
5.	EMI Power Line Filter	DUOJI EME	FNF 201 B16	N/A	Nov. 20, 2021	1 Year
6.	EMI Power Line Filter	JIANLI	DL-40C	N/A	Nov. 20, 2021	1 Year
7.	Cable	Schwarzbeck	AK9513	ACRX1	Nov. 20, 2021	1 Year
8.	Cable	Rosenberger	N/A	FP2RX2	Nov. 20, 2021	1 Year
9.	Cable	Schwarzbeck	AK9513	CRPX1	Nov. 20, 2021	1 Year
10.	Cable	Schwarzbeck	AK9513	CRRX2	Nov. 20, 2021	1 Year
11.	Signal Generator	HP	8648A	3625U00573	Nov. 20, 2021	1 Year

2.3. For Harmonic Current / Flicker Measurement

Item	Equipment	Manufacturer	Model No.	Serial No.	Last Cal.	Cal. Interval
1.	Power Frequency Test System	HAEFELY	PHF555	080419-03	Nov. 20, 2021	1 Year
2.	PC	N/A	P2L97	N/A	Nov. 20, 2021	N/A

2.4. For Electrostatic Discharge Immunity Test

Item	Equipment	Manufacturer	Model No.	Serial No.	Last Cal.	Cal. Interval
1.	ESD Tester	HAEFELY	PESD1600	H708159	Nov. 20, 2021	1 Year



2.5. For RF Strength Susceptibility Test

Item	Equipment	Manufacturer	Model No.	Serial No.	Last Cal.	Cal. Interval
1.	Signal Generator	HP	8648A	3625U00573	Nov. 20, 2021	1 Year
2.	Amplifier	AR	500A100	17034	NCR	NCR
3.	Amplifier	AR	100W/1000M1	17028	NCR	NCR
4.	Isotropic Field Monitor	AR	FM2000	16829	NCR	NCR
5.	Isotropic Field Probe	AR	FP2000	16755	Nov. 20, 2021	1 Year
6.	Biconic Antenna	EMCO	3108	9507-2534	NCR	NCR
7.	Log-periodic Antenna	AR	AT1080	16812	NCR	NCR
8.	PC	N/A	486DX2	N/A	N/A	N/A

2.6. For Electrical Fast Transient /Burst Immunity Test

Item	Equipment	Manufacturer	Model No.	Serial No.	Last Cal.	Cal. Interval
1.	Burst Tester	HAEFELY	PEFT4010	080981-16	Nov. 20, 2021	1 Year
2.	Coupling Clamp	HAEFELY	IP-4A	147147	Nov. 20, 2021	1 Year

2.7. For Surge Immunity Test

Item	Equipment	Manufacturer	Model No.	Serial No.	Last Cal.	Cal. Interval
1.	Surge Tester	HAEFELY	PSURGE4.1	080107-04	Nov. 20, 2021	1 Year

2.8. For Injected Current Susceptibility Test

Item	Equipment	Manufacturer	Model No.	Serial No.	Last Cal.	Cal. Interval
1.	Simulator	EMTEST	CWS500C	0900-12	Nov. 20, 2021	1 Year
2.	CDN	EMTEST	CDN-M2	5100100100	Nov. 20, 2021	1 Year
3.	CDN	EMTEST	CDN-M3	0900-11	Nov. 20, 2021	1 Year
4.	Injection Clamp	EMTEST	F-2031-23 MM	368	Nov. 20, 2021	1 Year
5.	Attenuator	EMTEST	ATT6	0010222A	Nov. 20, 2021	1 Year

2.9. For Magnetic Field Immunity Test

Item	Equipment	Manufacturer	Model No.	Serial No.	Last Cal.	Cal. Interval
1.	Magnetic Field Tester	HAEFELY	MAG100	250040.1	Nov. 20, 2021	1 Year

2.10. For Voltage Dips and Interruptions Test

Item	Equipment	Manufacturer	Model No.	Serial No.	Last Cal.	Cal. Interval
1.	Dips Tester	HAEFELY	Pline1610	083732-12	Nov. 20, 2021	1 Year

3. POWER LINE CONDUCTED EMISSION MEASUREMENT

3.1. Block Diagram of Test Setup

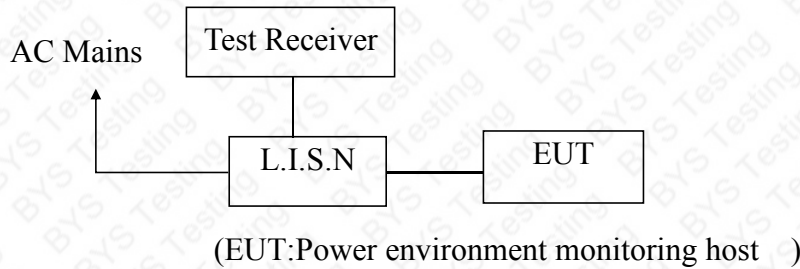

3.2. Measuring Standard

EN 55032:2015+A1:2020

Power Line Conducted Emission Limits (Class B)

Frequency (MHz)	Limit (dB μ V)	
	Quasi-Peak Level	Average Level
0.15 ~ 0.50	66.0 ~ 56.0 *	56.0 ~ 46.0 *
0.50 ~ 5.00	56.0	46.0
5.00 ~ 30.00	60.0	50.0

NOTE1-The lower limit shall apply at the transition frequencies.
 NOTE2-The limit decreases linearly with the logarithm of the frequency in the range 0.15MHz to 0.50MHz.

3.3. EUT Configuration on Measurement

The following equipments are installed on Conducted Emission Measurement to meet EN55032 requirements and operating in a manner which tends to maximize its emission characteristics in a normal application.

EUT : Power environment monitoring host
 Model Number : HW-6100G



3.4. Operating Condition of EUT

- 3.4.1. Setup the EUT as shown on Section 3.1.
- 3.4.2. Turn on the power of all equipments.
- 3.4.3. Let the EUT work in measuring mode (On) and measure it.

3.5. Test Procedure

The EUT is put on the plane 0.8m high above the ground by insulating support and connected to the AC mains through Line Impedance Stability Network (L.I.S.N). This provided a 50ohm coupling impedance for the tested equipments. Both sides of AC line are investigated to find out the maximum conducted emission according to the EN55032 regulations during conducted emission measurement.

The bandwidth of the field strength meter (R&S Test Receiver ESCS30) is set at 9KHz in 150KHz~30MHz and 200Hz in 9KHz~150KHz.

The frequency range from 150kHz to 30MHz is investigated

3.6 Measuring Results

PASS

Please reference to the following pages



Conducted Emission

EUT : Power environment monitoring host Date : 2022-03-21
 Model : HW-6100G Power Supply : AC100V-240V
 50/60Hz
 Mode : Normal Working Phase : L-line

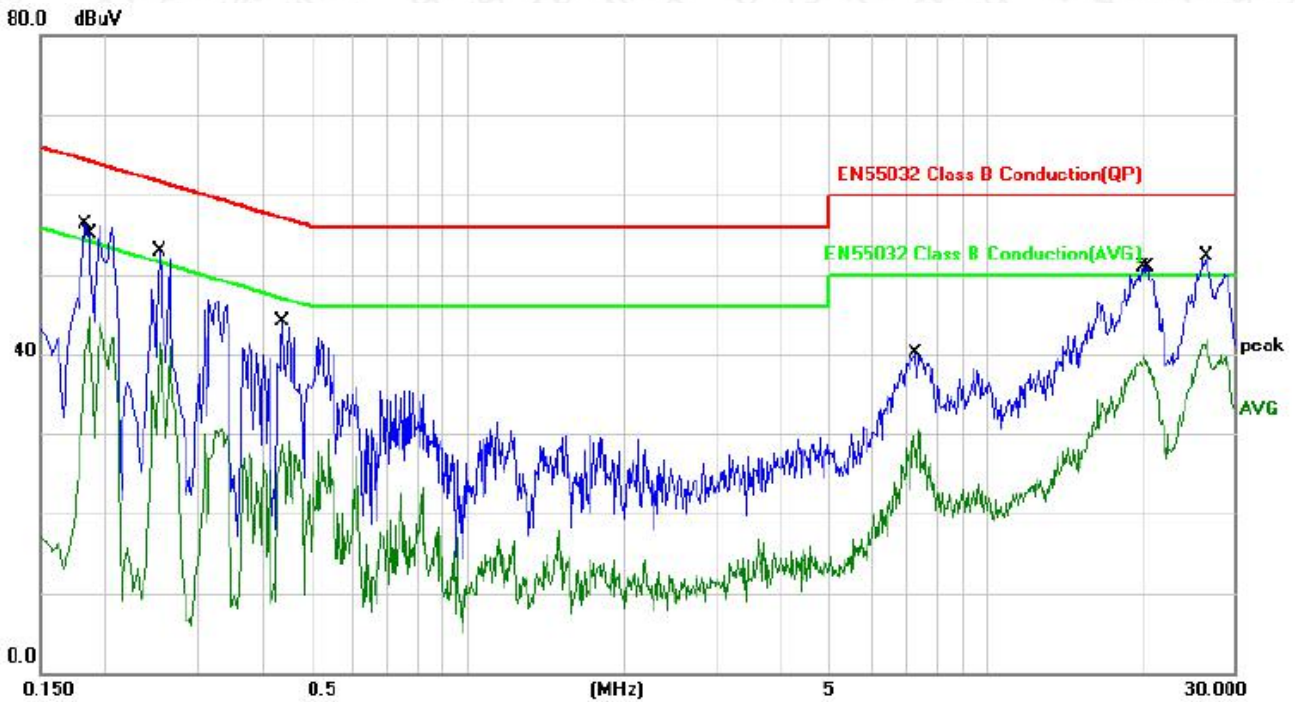

No.	Mk.	Freq. MHz	Reading Level dBuV	Correct Factor dB	Measure- ment dBuV	Limit dBuV	Over dB	Detector	Comment
1		0.1824	56.47	-0.13	56.34	64.37	-8.03	QP	
2		0.1864	42.03	-0.13	41.90	54.19	-12.29	AVG	
3		0.2540	53.11	-0.11	53.00	61.62	-8.62	QP	
4		0.2540	41.66	-0.11	41.55	51.62	-10.07	AVG	
5		0.4380	44.10	-0.02	44.08	57.10	-13.02	QP	
6		0.4380	28.68	-0.02	28.66	47.10	-18.44	AVG	
7		7.3178	40.34	-0.28	40.06	60.00	-19.94	QP	
8		7.3779	30.74	-0.28	30.46	50.00	-19.54	AVG	
9		20.1140	40.30	-0.37	39.93	50.00	-10.07	AVG	
10		20.3979	51.33	-0.38	50.95	60.00	-9.05	QP	
11		26.4499	42.38	-0.43	41.95	50.00	-8.05	AVG	
12	*	26.5779	52.79	-0.42	52.37	60.00	-7.63	QP	



Conducted Emission

EUT : Power environment monitoring host Date : 2022-03-21
 Model : HW-6100G Power : AC100V-240V
 Mode : Normal Working Supply : 50/60Hz
 Phase : N-line

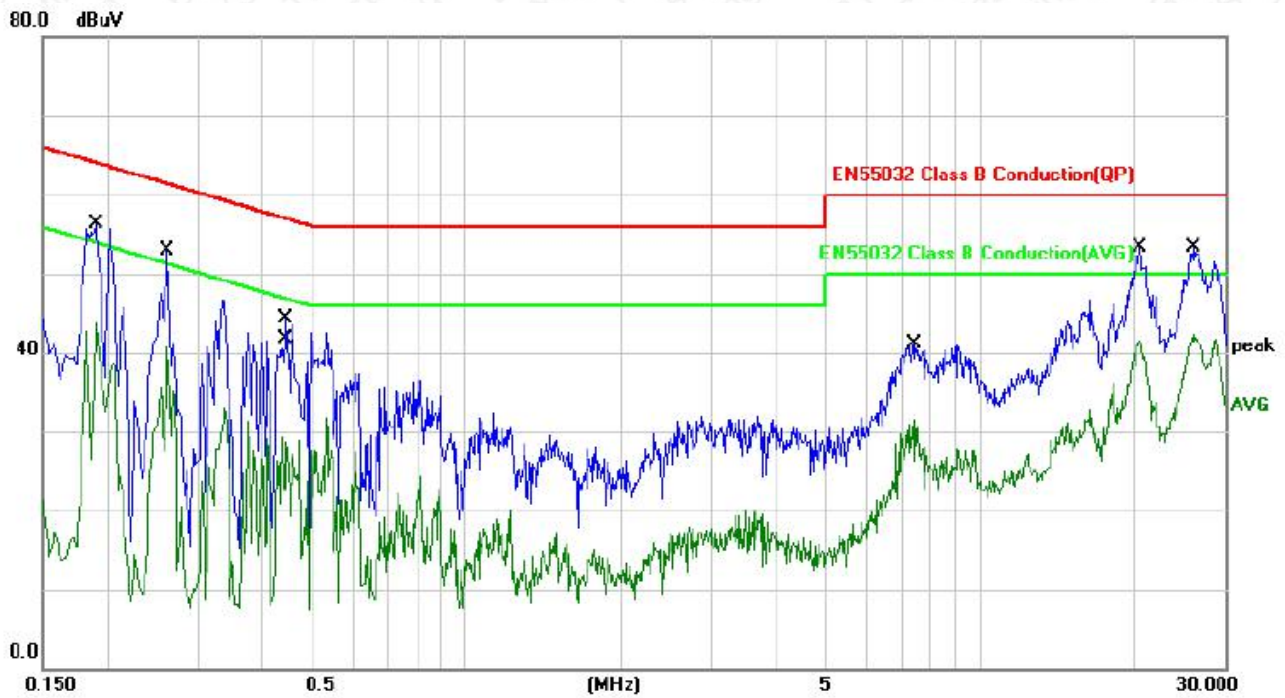

No.	Mk.	Freq. MHz	Reading Level dBuV	Correct Factor dB	Measure- ment dBuV	Limit dBuV	Over dB	Detector	Comment
1		0.1900	56.51	-0.13	56.38	64.03	-7.65	QP	
2		0.1900	43.93	-0.13	43.80	54.03	-10.23	AVG	
3		0.2620	52.94	-0.11	52.83	61.36	-8.53	QP	
4		0.2620	40.81	-0.11	40.70	51.36	-10.66	AVG	
5		0.4380	29.28	-0.02	29.26	47.10	-17.84	AVG	
6		0.4460	44.33	-0.02	44.31	56.95	-12.64	QP	
7		7.4378	41.40	-0.28	41.12	60.00	-18.88	QP	
8		7.4378	31.85	-0.28	31.57	50.00	-18.43	AVG	
9		20.3779	53.62	-0.38	53.24	60.00	-6.76	QP	
10		20.3779	41.91	-0.38	41.53	50.00	-8.47	AVG	
11	*	26.0859	53.86	-0.46	53.40	60.00	-6.60	QP	
12		26.0859	42.78	-0.46	42.32	50.00	-7.68	AVG	

4. RADIATED EMISSION MEASUREMENT

4.1. Block Diagram of Test

4.1.1. Block diagram of test setup (In chamber)

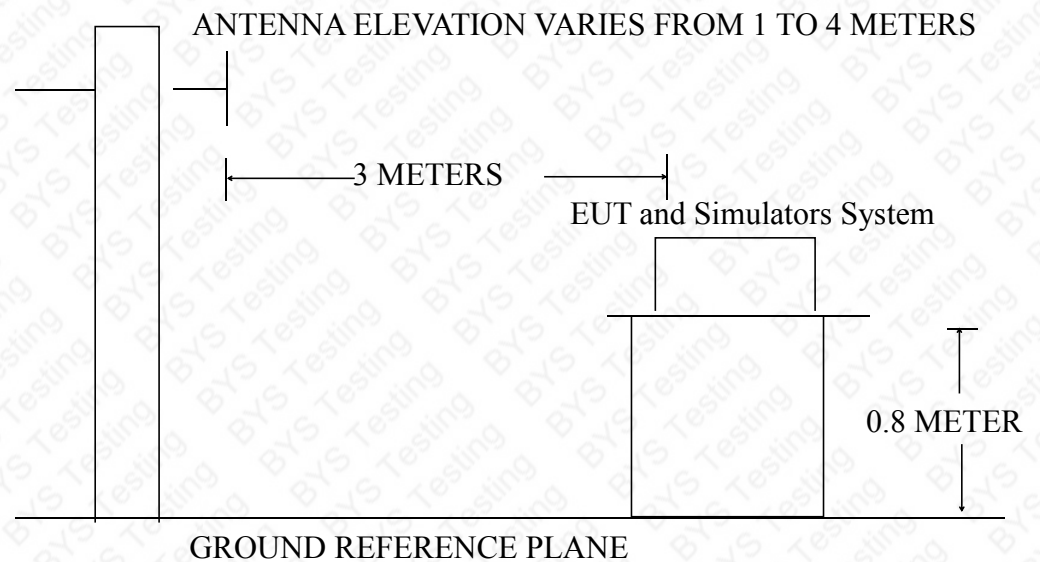

(EUT: Power environment monitoring host)

4.2. Measuring Standard

EN 55032:2015+A1:2020



4.3. Radiated Emission Limits

All emanations from a class B device or system, including any network of conductors and apparatus connected thereto, shall not exceed the level of field strengths specified below:

FREQUENCY (MHz)	DISTANCE (Meters)	FIELD STRENGTHS LIMIT (dB μ V/m)
30 ~ 230	3	40
230 ~ 1000	3	47

- Note: (1) The smaller limit shall apply at the combination point between two frequency bands.
(2) Distance refers to the distance in meters between the measuring instrument antenna and the closed point of any part of the EUT.

4.4. EUT Configuration on Test

The EN55032 regulations test method must be used to find the maximum emission during radiated emission measurement.

4.5. Operating Condition of EUT

4.5.1. Turn on the power.

4.5.2. After that, let the EUT work in test mode (Normal) and measure it.

4.6. Test Procedure

The EUT is placed on a turn table which is 0.8 meter high above the ground. The turn table can rotate 360 degrees to determine the position of the maximum emission level. The EUT is set 3 meters away from the receiving antenna which is mounted on a antenna tower. The antenna can be moved up and down from 1 to 4 meters to find out the maximum emission level. Bilog antenna (calibrated by Dipole Antenna) is used as a receiving antenna. Both horizontal and vertical polarization of the antenna are set on test.

The bandwidth of the Receiver (ESCS30) is set at 120kHz.
The frequency range from 30MHz to 1000MHz is investigated.

4.7. Measuring Results

PASS.

Please reference to the following pages



Radiated Emission Test Data

Standard:	EN55032 Class B RE	Polarization:	Horizontal
Test item:	Radiation Test	Date:	2022-03-21
EUT:	Power environment monitoring host	Test By:	Mark
Model:	HW-6100G	Distance:	3m
Note:			



No.	Mk.	Freq. MHz	Reading Level dBuV	Correct Factor dB/m	Measure- ment dBuV/m	Limit dBuV/m	Over dB	Antenna Height cm	Table Degree degree	Comment
1		33.0950	29.63	-6.16	23.47	40.00	-16.53	QP		
2		47.4918	41.27	-16.57	24.70	40.00	-15.30	QP		
3	*	79.5209	51.43	-18.65	32.78	40.00	-7.22	QP		
4		160.3456	43.53	-13.02	30.51	43.50	-12.99	QP		
5		187.7530	46.44	-14.37	32.07	43.50	-11.43	QP		
6		204.9551	48.12	-14.08	34.04	43.50	-9.46	QP		



Radiated Emission Test Data

Standard:	EN55032 Class B RE	Polarization:	Vertical
Test item:	Radiation Test	Date:	2022-03-21
EUT:	Power environment monitoring host	Test By:	Mark
Model:	HW-6100G	Distance:	3m
Note:			



No.	Mk.	Freq.	Reading Level	Correct Factor	Measurement	Limit	Over	Antenna Height	Table Degree	
		MHz	dBuV	dB/m	dBuV/m	dBuV/m	dB	cm	degree	Comment
1	!	30.3173	39.89	-5.17	34.72	40.00	-5.28	QP		
2		67.4382	49.45	-18.78	30.67	40.00	-9.33	QP		
3		80.3619	48.21	-18.84	29.37	40.00	-10.63	QP		
4	*	99.8777	53.46	-15.02	38.44	43.50	-5.06	QP		
5		112.5244	46.86	-13.13	33.73	43.50	-9.77	QP		
6		124.1330	44.78	-12.30	32.48	43.50	-11.02	QP		

5. HARMONIC CURRENT EMISSION MEASUREMENT

5.1 Block Diagram of Test Setup

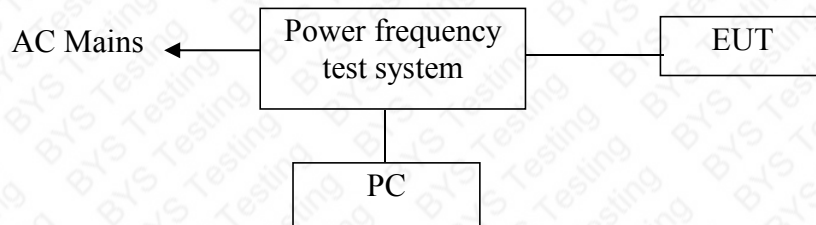

(EUT: Power environment monitoring host)

5.2 Measuring Standard

EN 61000-3-2: 2014

5.3 Operation Condition of EUT

Same as Section 3.4, except the test setup replaced as Section 5.1.

5.4 Measuring Results

N/A (Below 75W)

6.VOLTAGE FLUCTUATION AND FLICKER EASUREMENT

6.1Block Diagram of Test Setup

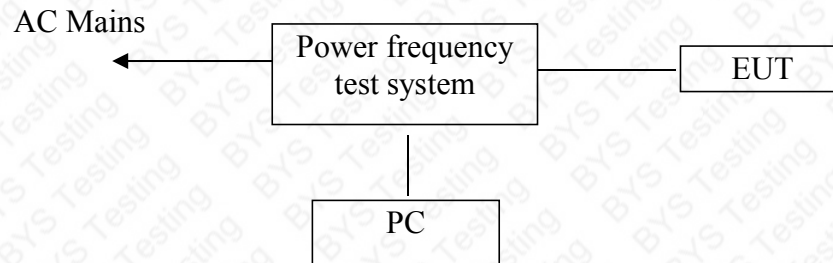

(EUT: Power environment monitoring host)

6.2Measuring Standard

EN61000-3-3:2013

6.3 Operation Condition of EUT

- 6.3.1 Setup the EUT and simulators as shown in Section6.1.
- 6.3.2 Turn on the power of all equipments.
- 6.3.3 Let the EUT work in test modes (Normal) and test it.

6.4 Measuring Results

PASS

Please reference to the following page



EN 61000-3-3 TEST REPORT 2022-03-21 16:23

Unit: Power environment monitoring host M/N: HW-6100G
 Test mode: Normal Working
 Manuf: SEASONAL DEALS LTD
 Operator: Mark

TEST SETUP

Test Freq.: 50.00 Hz. Test Voltage: 230.0 vac
 Waveform: SINE
 Test Time: 120.0 min. Tshort: 10.0 min.
 Prog. Zo Enabled: YES Prog. Zo: 0.000
 Voltage Change less than once per Hour: NO
 Impedance selected: IEC-725 STD. REF.
 Synthetic R+L Enabled: NO
 Resistance: 0.380 Ohms Inductance: 460.000 uH

TEST DATA

Result:	PASS			
	EUT Data	Limit	Result	Test Enabled
Pst max	0.189	1.00	PASS	true
Plt max	0.166	0.65	PASS	true
dc %	0.00	3.00	PASS	true
dmax %	1.32	4.00	PASS	true
d(t) sec.	0.00	0.20	PASS	true
Power Source Data				
Source Pst max	0.231	0.400	PASS	true
% THD	0.03	3.00	PASS	true

7. ELECTROSTATIC DISCHARGE IMMUNITY TEST

7.1 Block Diagram of Test Setup

7.1.1 Block Diagram of the EUT and the simulators



7.1.2 Block diagram of ESD test setup

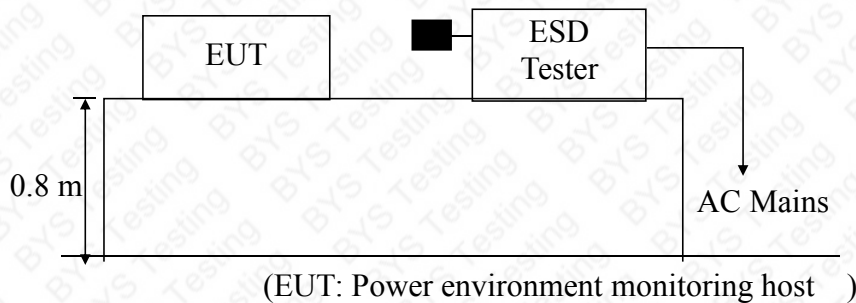

7.2 Test Standard

SHENZHEN BYS TESTING CO., LTD(EN61000-4-2: 2009)

Severity Level: 3 / Air Discharge: $\pm 8KV$ Level: 2 / Contact Discharge: $\pm 4KV$)

7.3 Severity Levels and Performance Criterion

7.3.1 Severity level

Level	Test Voltage Contact Discharge (KV)	Test Voltage Air Discharge (KV)
1.	± 2	± 2
2.	± 4	± 4
3.	± 6	± 8
4.	± 8	± 15
X	Special	Special

7.3.2 Performance criterion: **B**

7.4 EUT Configuration

The configuration of EUT is listed in Section 3.3.



7.5 Operating Condition of EUT

Same as conducted emission measurement, which is listed in Section 3.4. Except the test set up replaced by Section 7.1.

7.6 Test Procedure

7.6.1 Air Discharge:

This test is done on a non-conductive surface. The round discharge tip of the discharge electrode shall be approached as fast as possible to touch the EUT. After each discharge, the discharge electrode shall be removed from the EUT. The generator is then re-triggered for a new single discharge and repeated 10 times for each pre-selected test point. This procedure shall be repeated until all the air discharge completed.

7.6.2 Contact Discharge:

All the procedure shall be same as Section 7.6.1. except that the tip of the discharge electrode shall touch the EUT before the discharge switch is operated.

7.6.3 Indirect discharge for horizontal coupling plane

At least 10 single discharges (in the most sensitive polarity) shall be applied at the front edge of each HCP opposite the center point of each unit (if applicable) of the EUT and 0.1m from the front of the EUT. The long axis of the discharge electrode shall be in the plane of the HCP and perpendicular to its front edge during the discharge.

7.6.4 Indirect discharge for vertical coupling plane

At least 10 single discharge (in the most sensitive polarity) shall be applied to the center of one vertical edge of the coupling plane. The coupling plane, of dimensions 0.5m X 0.5m, is placed parallel to, and positioned at a distance of 0.1m from the EUT. Discharges shall be applied to the coupling plane, with this plane in sufficient different positions that the four faces of the EUT are completely illuminated.

7.7 Test Results

PASS

Please refer to the following page



Electrostatic Discharge Test Result

SHENZHEN BYS TESTING CO., LTD.

Applicant	: SEASONAL DEALS LTD	Test Date	: 2022-03-21
EUT	: Power environment monitoring host	Temperature	: 22℃
M/N	: HW-6100G	Humidity	: 50%
Power Supply	: AC100-250V 50/60Hz	Test Mode	: Normal
Air discharge	: ±2.0KV, ±4.0KV, ±6.0KV, ±8.0KV	Criterion	: B
Contact discharge:	±2.0KV, ±4.0KV	Test Engineer	: Mark

Location	Kind A-Air Discharge C-Contact Discharge	Result
Gap 10 points	A	PASS
LED 10 points	A	PASS
Button 10 points	A	PASS
Screw 10 points	C	PASS
HCP 4 points	C	PASS
VCP 4 points	C	PASS

Test Equipment: ESD Simulator (HAEFELY, PESD1600)

8. RF FIELD STRENGTH SUSCEPTIBILITY TEST

8.1 Block Diagram of Test

8.1.1 Block diagram of connection between the EUT and Load

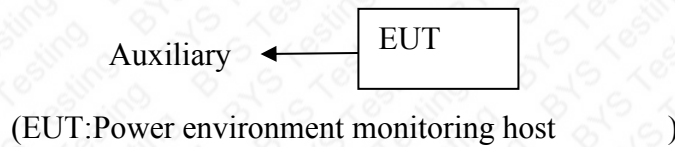

8.1.2 Block diagram of RS test setup

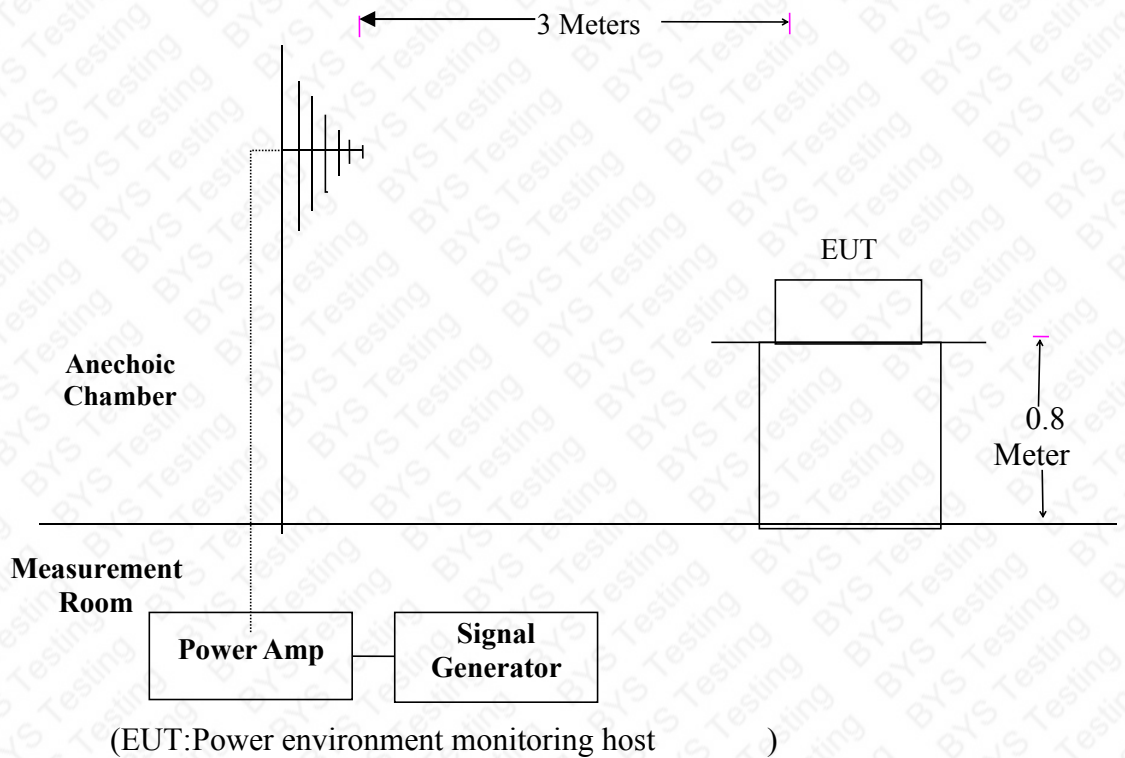

8.2 Test Standard

SHENZHEN BYS TESTING CO., LTD(EN61000-4-3: 2006 (Severity Level: 2, 3V / m))

8.3 Severity Levels and Performance Criterion

8.3.1 Severity Levels

Level	Field Strength V/m
1.	1
2.	3
3.	10
X	Special

8.3.2 Performance Criterion : A

8.4 EUT Configuration on Test

The configuration of the EUT is same as Section 3.3.

8.5 Operating Condition of EUT

Same as radiated emission measurement which is listed in Section 3.4, except the test setup replaced as Section 8.1.

8.6 Test Procedure

The EUT are placed on a table which is 0.8 meter high above the ground. The EUT is set 3 meters away from the transmitting antenna which is mounted on an antenna tower. Both horizontal and vertical polarization of the antenna are set on test. Each of the four sides of the EUT must be faced this transmitting antenna and measured individually. In order to judge the EUT performance, a CCD camera is used to monitor its screen. All the scanning conditions are as following:

Condition of Test	Remark
1. Fielded Strength	3V/m (Severity Level 2)
2. Radiated Signal	Modulated
3. Scanning Frequency	80-1000MHz
4. Sweep time of radiated	0.0015 Decade/s
5. Dwell Time	1 Sec.

8.7 Test Results

PASS.

Please refer to the following page.



RF Field Strength Susceptibility Test Results

SHENZHEN BYS TESTING CO., LTD

Applicant	: SEASONAL DEALS LTD	Test Date	: 2022-03-21	
EUT	: Power environment monitoring host	Temperature	: 22°C	
M/N	: HW-6100G	Humidity	: 50 %	
Field Strength	: 3 V/m	Criterion	: A	
Power Supply	: AC100-250V 50/60Hz, 4000Wmax.	Test Mode	: Normal	
Test Engineer	: Mark	Frequency Range	: 80 MHz to 1000 MHz	
Modulation:		<input type="checkbox"/> None	<input type="checkbox"/> Pulse <input checked="" type="checkbox"/> AM 1KHz 80%	
	Frequency Rang 1: 80~ 1000MHz	Frequency Rang 2:		
Steps	1 / %	# / %		
	Horizontal	Vertical	Horizontal	Vertical
Front	PASS	PASS		
Right	PASS	PASS		
Rear	PASS	PASS		
Left	PASS	PASS		
Test Equipment :				
1. Signal Generator : 2031 (MARCONI)				
2. Power Amplifier : 500A100 & 100W/1000M1 (A&R)				
3. Power Antenna : 3108 (EMCO) & AT1080 (A&R)				
4. Field Monitor : FM2000 (A&R)				
Note:				

9. ELECTRICAL FAST TRANSIENT/BURST IMMUNITY TEST

9.1 Block Diagram of Test Setup

9.1.1. Block Diagram of the EUT

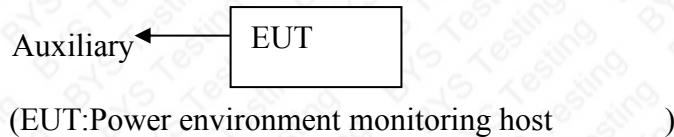

9.1.2. EFT Test Setup

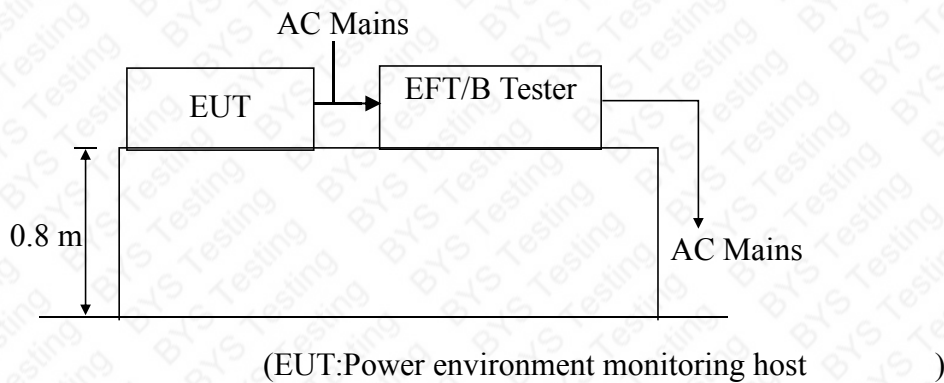

9.2 Test Standard

SHENZHEN BYS TESTING CO., LTD(EN61000-4-4:2004+A1:2010, Severity Level, Level 2: 1KV)

9.3 Severity Levels and Performance Criterion

9.3.1 Severity level

Level	Open Circuit Output Test Voltage $\pm 10\%$	
	On Power environment monitoring host Lines	On I/O (Input/Output) Signal data and control lines
1.	0.5 KV	0.25 KV
2.	1 KV	0.5 KV
3.	2 KV	1 KV
4.	4 KV	2 KV
X	Special	Special

9.3.2 Performance criterion : B



9.4 EUT Configuration

The configuration of EUT is listed in Section 3.3.

9.5 Operating Condition of EUT

9.5.1 Setup the EUT as shown in Section 9.1.

9.5.2 Turn on the power of all equipments.

9.5.3 Let the EUT work in test mode (Normal) and measure it.

9.6 Test Procedure

The EUT is put on the table which is 0.8 meter high above the ground. This reference ground plane shall project beyond the EUT by at least 0.1m on all sides and the minimum distance between EUT and all other conductive structure, except the ground plane beneath the EUT, shall be more than 0.5m.

9.6.1 For input and output AC power ports:

The EUT is connected to the power mains by using a coupling device which couples the EFT interference signal to AC power lines. Both polarities of the test voltage should be applied during compliance test and the duration of the test is 2 mins.

9.6.2 For signal lines and control lines ports:

No I/O ports. It's unnecessary to test.

9.6.3 For DC output line ports:

It's unnecessary to test.

9.7 Test Result

PASS

Please reference to the following page



Electrical Fast Transient/Burst Test Results

SHENZHEN CCT TESTING TECHNOLOGY CO., LTD

Standard	<input type="checkbox"/> IEC 61000-4-4 <input checked="" type="checkbox"/> EN 61000-4-4	Result : <input checked="" type="checkbox"/> PASS / <input type="checkbox"/> FAIL	
Applicant : SEASONAL DEALS LTD			
EUT : <u>Power environment monitoring host</u>		M/N : <u>HW-6100G</u>	
Input Voltage: <u>AC100-250V 50/60Hz</u>			
Criterion : B			
Ambient Condition : <u>20 °C</u>		<u>50% RH</u>	
Operation Mode : Normal			
Line : <input checked="" type="checkbox"/> AC Mains		Line : <input type="checkbox"/> Signal line <input type="checkbox"/> DC line	
Coupling : <input checked="" type="checkbox"/> Direct		Coupling : <input type="checkbox"/> Capacitive	
Test Time : 120s			
Line	Test Voltage	Result(+)	Result(-)
L	1KV	PASS	PASS
N	1KV	PASS	PASS
L、N	1KV	PASS	PASS
Note:			
Test Equipment		Burst Tester Model : PEFT 4010	

10. SURGE IMMUNITY TEST

10.1 Block Diagram of Test Setup

10.1.1 Block Diagram of the EUT

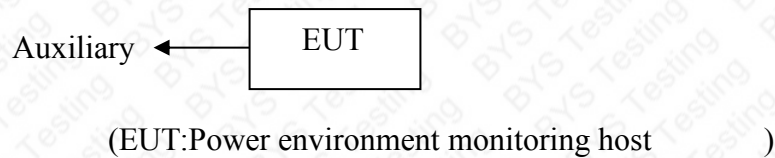

10.1.2. Surge Test Setup

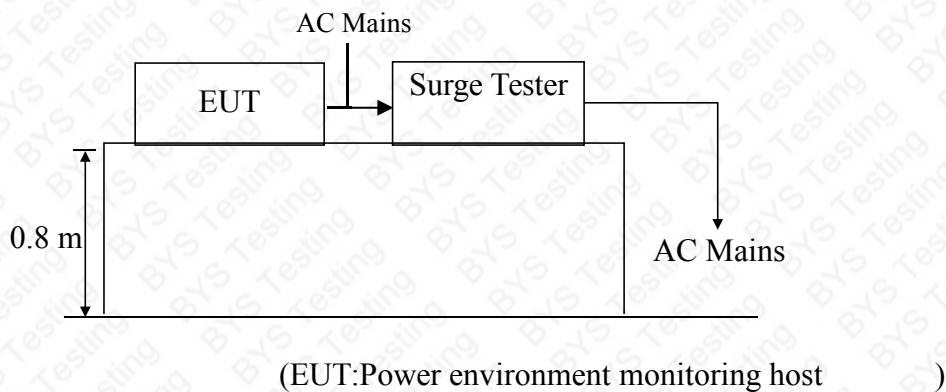

10.2 Test Standard

SHENZHEN BYS TESTING CO., LTD(EN61000-4-5: 2006)

Severity Level: Line to Line: Level 2, 1.0KV

10.3 Severity Levels and Performance Criterion

10.3.1. Severity level

Severity Level	Open-Circuit Test Voltage KV
1	0.5
2	1.0
3	2.0
4	4.0
*	Special

10.3.2 Performance criterion: **B**



10.4 EUT Configuration

The configuration of EUT is listed in Section 3.3.

10.5 Operating Condition of EUT

10.5.1 Setup the EUT as shown in Section 10.1.

10.5.2. Turn on the power of all equipments.

10.5.3. Let the EUT work in test mode (Normal) and measure it.

10.6 Test Procedure

- 1) Set up the EUT and test generator as shown on Section 10.1.2.
- 2) For line to line coupling mode, provide a 1.0 KV 1.2/50us voltage surge (at open-circuit condition) and 8/20us current surge to EUT selected points.
- 3) At least 5 positive and 5 negative (polarity) tests with a maximum 1/min repetition rate are conducted during test.
- 4) Different phase angles are done individually.
- 5) Record the EUT operating situation during compliance test and decide the EUT immunity criterion for above each test.

10.7 Test Result

PASS

Please reference to the following page



Surge Immunity Test Result

SHENZHEN BYS TESTING CO., LTD

Applicant : <u>SEASONAL DEALS LTD</u>				Test Date : <u>2022-03-21</u>	
EUT : <u>Power environment monitoring host</u>				Temperature : <u>22°C</u>	
M/N : <u>HW-6100G</u>				Humidity : <u>50%</u>	
Power Supply : <u>AC100-250V 50/60Hz</u>				Test Mode : <u>Normal</u>	
Test Engineer : <u>Mark</u>				Criterion : <u>B</u>	
Location	Polarity	Phase Angle	Number of Pulse	Pulse Voltage (KV)	Result
L-N	+	0°	5	1.0	PASS
	+	90°	5	1.0	PASS
	+	180°	5	1.0	PASS
	+	270°	5	1.0	PASS
	-	0°	5	1.0	PASS
	-	90°	5	1.0	PASS
	-	180°	5	1.0	PASS
	-	270°	5	1.0	PASS
Remark:				Test Equipment : Surge Tester P Surge4.1	

11. INJECTED CURRENTS SUSCEPTIBILITY TEST

11.1 Block Diagram of Test Setup

11.1.1 Block Diagram of the EUT



11.1.2 Block Diagram of Test Setup

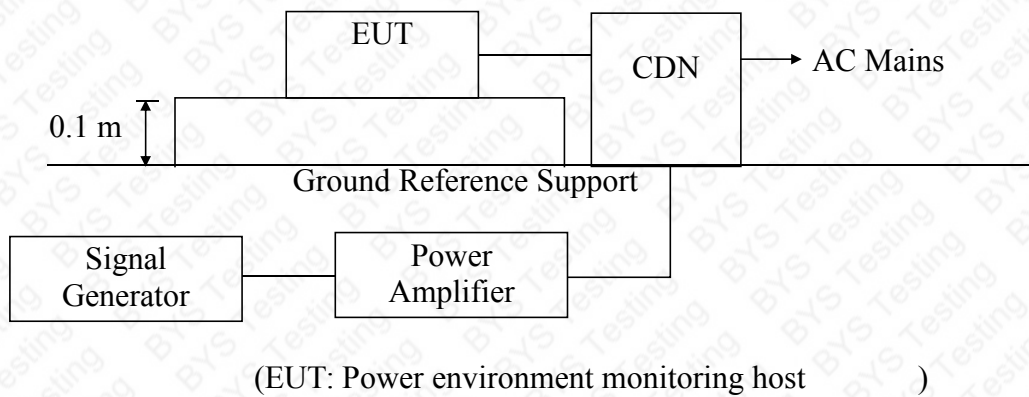

11.2 Test Standard

SHENZHEN BYS TESTING CO., LTD (EN61000-4-6: 2009, Severity Level: Level 2, 3V (rms), (0.15MHz ~ 80MHz)

11.3 Severity Levels and Performance Criterion

11.3.1 Severity level

Level	Field Strength V
1	1
2	3
3	10
X	Special

11.3.2 Performance criterion: A



11.4 EUT Configuration

The configuration of EUT is listed in Section 3.3.

11.5 Operating Condition of EUT

11.5.1 Setup the EUT as shown in Section 11.1.

11.5.2 Turn on the power of all equipments.

11.5.3 Let the EUT work in test mode (Normal) and measure it.

11.6 Test Procedure

- 1) Set up the EUT, CDN and test generators as shown on Section 11.1.2.
- 2) Let the EUT work in test mode and measure it.
- 3) The EUT are placed on an insulating support 0.1m high above a ground reference plane. CDN (coupling and decoupling device) is placed on the ground plane about 0.3m from EUT. Cables between CDN and EUT are as short as possible, and their height above the ground reference plane shall be between 30 and 50 mm (where possible).
- 4) The disturbance signal described below is injected to EUT through CDN.
- 5) The EUT operates within its operational mode(s) under intended climatic conditions after power on.
- 6) The frequency range is swept from 150KHz to 80MHz using 3V signal level, and with the disturbance signal 80% amplitude modulated with a 1KHz sine wave.
- 7) The rate of sweep shall not exceed 1.5×10^{-3} decades/s. Where the frequency is swept incrementally, the step size shall not exceed 1% of the start and thereafter 1% of the preceding frequency value.
- 8) Recording the EUT operating situation during compliance testing and decide the EUT immunity criterion.

11.7 Test Results

PASS

Please reference to the following page



Injected Currents Susceptibility Test Results

SHENZHEN BYS TESTING CO., LTD

Applicant : <u>SEASONAL DEALS LTD</u>		Test Date: <u>2022-03-21</u>		
EUT : <u>Power environment monitoring host</u>		Temperature : <u>22°C</u>		
M/N : <u>HW-6100G</u>		Humidity : <u>58%</u>		
Power Supply : <u>AC100-250V 50/60Hz</u>				
Test Engineer : <u>Mark</u>				
Test Mode : <u>Normal</u>				
Frequency Range (MHz)	Injected Position	Strength (Unmodulated)	Criterion	Result
0.15 ~ 80	AC Mains	3V	A	PASS
Test Mode : _____				
Frequency Range (MHz)	Injected Position	Strength (Unmodulated)	Criterion	Result
Remark : 1. Modulation Signal:1KHz 80% AM Measurement Equipment : Simulator: CWS 500 (SWITZERLAND EMTEST) CDN : <input checked="" type="checkbox"/> CDN-M2 (SWITZERLAND EMTEST) <input checked="" type="checkbox"/> CDN-M3 (SWITZERLAND EMTEST)		Note:		

12. MAGNETIC FIELD SUSCEPTIBILITY TEST

12.1 Block Diagram of Test

12.1.1 Block diagram of test setup



(EUT: Power environment monitoring host)

12.1.2 Magnetic field test setup

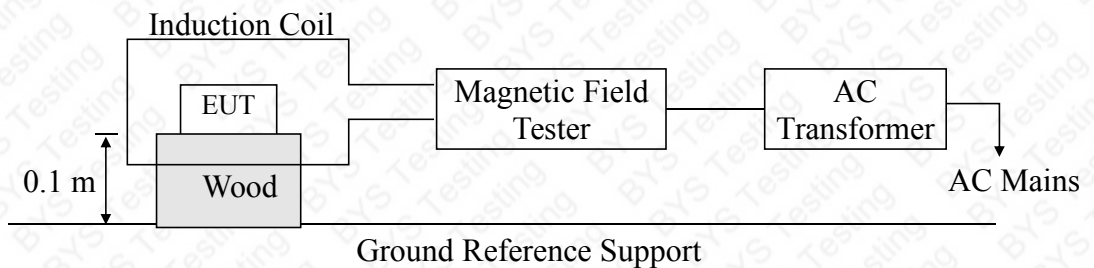

(EUT: Power environment monitoring host)

12.2 Test Standard

SHENZHEN BYs TESTING CO., LTD (EN61000-4-8: 2010, Severity Level: Level 1, 1A / m)

12.3 Severity Levels and Performance Criterion

12.3.1 Severity Levels

Level	Field Strength A/m
1	1
2	3
3	10
4	30
5	100
X	Special

12.3.2 Performance Criterion: A



12.4 EUT Configuration on Test

The configuration of the EUT is same as Section 3.3.

12.5 Test Procedure

The EUT is placed in the middle of a induction coil (1*1m), under which is a 1*1*0.1m (high) table, this small table is also placed on a larger table,0.8 m above the ground. Both horizontal and vertical polarization of the induction coil are set on test, so that each side of the EUT is affected by the magnetic field. Also can reach the same aim by change the position of the EUT.

12.6 Test Results

PASS

Please reference to the following page



Magnetic Field Immunity Test Result

SHENZHEN BYS TESTING CO., LTD

Standard	<input type="checkbox"/> IEC 61000-4-8 <input checked="" type="checkbox"/> EN 61000-4-8		Result: <input checked="" type="checkbox"/> Pass / <input type="checkbox"/> Fail	
Applicant	: SEASONAL DEALS LTD			
EUT	: Power environment monitoring host		M/N:	HW-6100G
Input Voltage	: AC100-250V 50/60Hz,			
Date of Test	: 2022-03-21	Test Engineer:	Mark	
Ambient Condition	: Temp	: 22°C	Humid:	58%
Criterion: A				
Operation Mode : <u>Normal</u>				
Test Level (A/M)	Testing Duration	Coil Orientation	Criterion	Result
1	5 mins	X	A	PASS
1	5 mins	Y	A	PASS
1	5 mins	Z	A	PASS
Operation Mode :				
Test Level (A/M)	Testing Duration	Coil Orientation	Criterion	Result
Test Equipment	Magnetic Field Test: HEAFELY MAG 100.1			
Note:				

13. VOLTAGE DIPS AND INTERRUPTIONS TEST

13.1 Block Diagram of Test Setup

13.1.1 Block Diagram of the EUT



13.1.2 Dips Test Setup

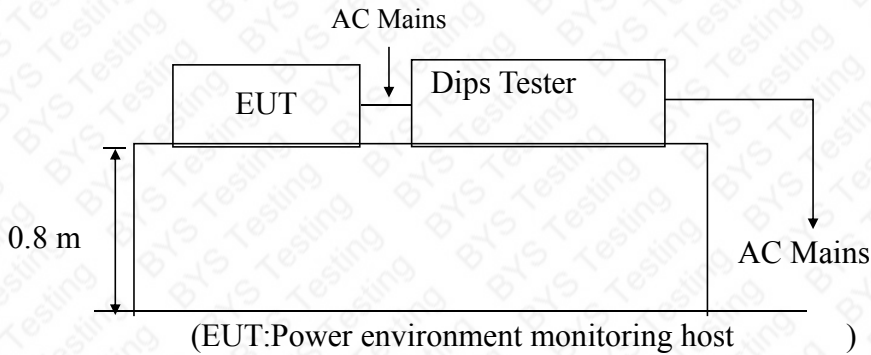

13.2 Test Standard

SHENZHEN BYs TESTING CO., LTD(EN61000-4-11: 2004)



13.3 Severity Levels and Performance Criterion

13.3.1 Severity level

Test Level %UT	Voltage dip and short interruptions %UT	Duration (in period)
0	100	0.5 1
40	60	5 10
70	30	25 50 *

13.3.2 Performance criterion : **B&C**

13.4 EUT Configuration

The configuration of EUT is listed in Section 3.3.

13.5 Operating Condition of EUT

13.5.1 Setup the EUT as shown in Section 13.1.

13.5.2 Turn on the power of all equipments.

13.5.3 Let the EUT work in test mode (Normal) and measure it.

13.6 Test Procedure

- 1) Set up the EUT and test generator as shown on Section 13.1.2.
- 2) The interruptions is introduced at selected phase angles with specified duration.
- 3) Record any degradation of performance.

13.7 Test Result

PASS

Please reference to the following page



Voltage Dips And Interruptions Test Results

SHENZHEN BYS TESTING CO., LTD

Applicant : <u>SEASONAL DEALS LTD</u>	Test Date : <u>2022-03-21</u>
EUT : <u>Power environment monitoring host</u>	Temperature : <u>22°C</u>
M/N : <u>HW-6100G</u>	Humidity : <u>50%</u>
Power Supply : <u>AC100-250V 50/60Hz</u>	Test Engineer : <u>Mark</u>

Test Mode: Normal

Test Level % U _T	Voltage Dips & Short Interruptions % U _T	Duration (in periods)	Criterion <input type="checkbox"/> A <input checked="" type="checkbox"/> B <input checked="" type="checkbox"/> C <input type="checkbox"/> D	Result P=PASS F=Fail
0	100	0.5P	B	P
40	60	250P	C	P
70	30	25P	C	P

Test Mode :

Test Level % U _T	Voltage Dips & Short Interruptions % U _T	Duration (in periods)	Criterion <input type="checkbox"/> A <input type="checkbox"/> B <input type="checkbox"/> C <input type="checkbox"/> D	Result P=PASS F=FAIL

Note:

FIGURE
GENERAL APPEARANCE OF EUT



Photo 1



Photo 2

*****THE END*****